



2300 Duplex Softener Manual

Installation / Operation Manual

Softener Specifications..... Page 3
Softener Installation..... Page 5
Service Information..... Page 8
Shuttle Powerhead..... Page 12
Shuttle Valve..... Page 13
Slave Powerhead..... Page 14
Slave Valve..... Page 15
Troubleshooting..... Page 13
Warranty..... Page 15

Register Your Product

Online at

www.clearionwater.com



General Specifications	CLAD48 CLAD48V	CLAD64 CLAD64V	CLAD96 CLAD96V	CLAD128 CLAD128V
Grains Capacity - Regeneration / Lbs Salt Used (Per Tank)**	24,000 / 12.0 20,000 / 7.5 15,000 / 4.5	32,000 / 15.0 27,000 / 9.0 20,000 / 6.0	48,000 / 24.0 40,000 / 15.0 30,000 / 9.0	64,000 / 30.0 54,000 / 18.0 40,000 / 12.0
Maximum Raw Water Hardness (grains)	50	75	100	100
Maximum Clear Iron / Manganese	3	5	5	5
Exchange Resin (cu. ft. per tank)	.75	1.0	1.5	2.0
Mineral Tanks (polyglass)	(2) 8 x 44	(2) 9 x 48	(2) 10 x 54	(2) 12 x 52
Brine Tank (polyethylene w grid & safety)	16 x 33	16 x 33	16 x 33	16 x 33
Service Flow Rate (gpm per active tank)	8.0	10.0	11.0	12.0
Backwash Flow Rate (gpm)	1.5	2.0	2.4	3.5
Gallons Used / Regeneration	79	90	101	140
Backwash Flow Rate (gpm) Vortech (V) Units	1.2	1.5	2.0	2.4
Gallons Used / Regeneration Vortech (V) Units	69	78	90	117
Space Required	16 x 34 x 52	16 x 34 x 56	16 x 36 x 62	16 x 40 x 60
Approximate Shipping Weight (lbs)	139	169	237	299

WARNING

Lubricants

Do NOT use Vaseline, oils, hydrocarbon lubricants or spray silicone anywhere! Petroleum base lubricants will cause swelling of o-rings and seals. The use of other lubricants may attack plastic Noryl®. It is recommended that Dow Corning® silicone grease be used as a lubricant for all control valves. Dow Corning® 7 Release Compound is used in the manufacture of Chandler Systems control valves. (Part # LT-150)

Sealants

Pipe dope and liquid thread sealers may contain a carrier that attacks some plastic materials. It is recommended that Teflon® tape be used to seal plastic Noryl® threaded fittings.

Softener Specifications

PLEASE NOTE THESE SPECIFICATIONS BEFORE PROCEEDING

OPERATING PRESSURE RANGE : 20 - 125 PSI
OPERATING TEMPERATURE RANGE : 33° F - 120° F
INLET / OUTLET PIPE SIZE : 3/4" FNPT

PLEASE COMPLY WITH ALL APPLICABLE PLUMBING CODES

PROTECT THE SOFTENER AND PIPING FROM FREEZING TEMPERATURES

Please read the entire Owner's Manual and Instructions before installation.
This Owner's Manual must stay with the unit.

How A Water Softener Works

Water hardness is derived from Calcium and Magnesium minerals that have been dissolved into water under the earth's surface. These minerals are found in limestone deposits and are the source of hard water. The amount of hardness in a given water supply is dependent upon the quantity of Calcium and Magnesium present and the length of time water has been in contact with them. This can vary dramatically from well-to-well and, for this reason, a water analysis is imperative in order to determine the proper treatment method. The degree of hardness increases as the concentration of Calcium and Magnesium "ions" increase and is measured in Grains Per Gallon (gpg).

The problem of hard water in the home / business comes to light in many facets of daily use. Water spots and scum left behind on bathtubs, fixtures and showers; wear and tear on appliances; calcium build-up in hot water heaters and piping; and greater amounts of soaps and detergents being used are just a few examples.

The modern water softener is designed to reduce hardness ions and their unpleasant side effects. Special resin beads in the softener mineral tank are used to change hard water into soft water. The surfaces of these beads, are covered with sodium ions. As hard water enters the mineral tank and comes into contact with the resin, an exchange of ions takes place as dissolved Calcium and Magnesium ions cling to the resin surface and sodium ions take their place, thus softening the water. This process is called Ion Exchange. Over time, the sodium ions used for the exchange process become depleted and must be replenished.

The water softener provides a Regeneration process whereby brine solution enters the mineral tank, driving-off the collected hardness ions and replenishes the surface of the resin beads with more sodium ions. This process is automatically initiated by the control valve on the mineral tank. The regeneration process has four basic cycles as follows:

1. **Backwash** - The control valve directs the water flow in a reverse direction through the mineral tank, separating the resin beads and flushing any accumulate particles to a waste drain.
2. **Brine & Rinse** - In the first part of this cycle, the control valve directs brine solution downward through the mineral tank, driving-off collected hardness ions and replenishing the resin beads with sodium ions. The second part of the cycle rinses hardness ions and excess brine from the mineral tank to the waste drain.
3. **Rapid Rinse** - The control valve directs the water flow downward, settling and recompacting the resin bed.
4. **Brine Refill** - The control valve directs fresh water into the brine tank to create new brine solution for the next scheduled regeneration.
5. **Service** - This is the normal "operating" cycle where hard water enters the mineral tank, comes into contact with the resin beads and exchanges hardness ions for sodium ions - the water then becomes "soft" and ready for use.

Pre-Installation Check List

A water test should always be performed in order to determine total water hardness (in gpg) and total dissolved iron (in parts per million - ppm). This is critical for proper equipment selection, sizing and for determining the program for regeneration frequency. If heavy concentrations of iron (above 5 ppm), iron coloration, iron bacteria or sediment are present, filtration prior to the softener will most generally be required. Certain states may require a licensed plumber for installation.

Note: Flexible water supply connectors and flexible drain line tubing may not be allowed in your locale. Please check with local plumbing code officials prior to installation.

Installation Requirements

- A level floor position ahead of piping into water heater.
- Unit must be installed at least 10 feet ahead of the inlet to a water heater to prevent damage due to back-up of hot water.
- DO NOT install the unit in an area of direct sunlight or where freezing temperatures may occur!

Major System Components:

1. **Brine Tank** - This tank holds the salt that is added to the softener. This salt is dissolved with water to form a brine solution used in the softener regeneration process.
2. **Resin Tank** - These tanks contain the ion exchange resin media. Water flows through the tanks under pressure to come into contact with the resin for water softening.
3. **Control Valve** - The valve directs water through the resin tank for water softening and controls the flow of water / brine for the regeneration process.

Softener Location / Other Requirements

- Locate the unit near an unswitched, 120 volt / 60 Hz grounded electrical outlet.
- Check the distance and proper drain installation (e.g. floor drain, washing machine standpipe).
- Determine type and size of piping required for softener connection (e.g. copper, galvanized, PVC plastic).

Note: If household plumbing is galvanized and you intend to make the installation with copper (or vice versa), obtain di-electric unions to prevent dissimilar metal corrosion.

Note: Where the drain line is elevated above the control valve or exceeds 20 feet in length to reach the drain, use 3/4" I.D. Drain line tubing instead of 1/2" I.D. Drain line tubing is not included.

Caution: If sweat soldering copper pipe (remember to always use lead free solder and flux), cover yoke or bypass valve with wet rags to prevent heat damage to connections and control valve!! If using PVC or plastic pipe, primers and solvent cements specifically recommended for use with potable water are required.

Note: All plumbing lines not requiring "soft" water should be connected "upstream" of the softener.

Installation Procedure

Water Supply Connections and Bypass Valve

To allow for softener servicing, swimming pool filling or lawn sprinkling, a manual bypass valve has been installed at the factory. The bypass valve allows hard water to be manually routed around the softener.

1. Position softener at desired location for installation. Tank marked (Unit 1) = left and tank marked (Unit 2) = right.
2. For **SD96V unit only** - The filling material is shipped separately from the tanks. Remove the valves by unscrewing from center hole. Leave distributor tube in tank while filling. Use a cork or tape to place over top of distributor tube to prevent material from entering tube while filling. Place funnel in hole. Pour several gallons of water in the tanks. Pour in the resin. Remove funnel and cork or tape from distributor tube. Replace the valves, being careful to position the distributor tube into the distributor tube pilot hole.
3. Install the included interconnect manifold assembly and fasten clips on shuttle valve (center) to both R & L tanks.
4. Turn OFF main water supply and OPEN nearest faucet to relieve pressure.
5. Cut main line and install appropriate elbows and extensions. Inlet and outlet connections on the bypass are 3/4" FNPT pipe size.

Caution: Raised arrows located on the sides of control valve body and bypass valve indicate proper direction of water flow. Install inlet and outlet piping in direction of arrows. It is recommended that a vacuum breaker be installed on the inlet plumbing.

Note: Bypass valve is packed separately. It is normal to have "play" in the bypass valve after installation.

Installation

6. Rotate lever on bypass valve to the bypass position (position of bypass lever is perpendicular to the inlet / outlet piping).
7. Turn the main supply line on to restore water service to the home.
8. OPEN nearest faucet to evacuate air and repressurized plumbing lines.
9. Check for leaks!

-Drain Line Connection-

1. Install 1/2" I.D. drain line tubing (not included) from both hose barb elbows to an open drain. Do not tee lines together. A 4" air gap between the end of the drain line and open drain is required to prevent waste water backflow. Keep the drain lines as short as possible. An overhead drain line can be used if necessary, but should discharge below the control valve. A syphon trap (taped loop) at the outlet of the drain line is advisable to keep the drain line full and assure correct flow during regeneration. Elbows or other fittings must be kept at a bare minimum.

Note: Where the drain lines are elevated above the control valve or exceed 20 feet in length, 3/4" I.D. drain line tubing should be used.

- Brine Line and Overflow Connection -

1. Position brine tank on a smooth, level surface near the softener resin tank. If necessary, the brine tank can be placed at a higher level than the resin tank, but never at a lower level.
2. Install 3/8" O.D. by 1/4" I.D. brine line tubing (included with unit) to 3/8 compression fitting on each control valve and into the brine line tee, as shown on page 8.
3. Remove brine tank cover.
4. Remove cap from brine well.
5. Insert opposite end of brine line through outer hole in brine tank.
6. Connect brine line to push lock fitting on safety brine valve located inside brine well.
7. Install 1/2" I.D. drain line tubing (not included) to the overflow fitting in brine tank located just below the brine line.
8. Run the opposite end of brine tank drain line to a suitable drain.

Note: The brine tank drain line is gravity flow and must discharge below the overflow fitting.

Caution: Do not "TEE" to the main drain lines from control valve.

Notice: The brine overflow is provided as a back-up in the event the safety float shut-off should fail, allowing the brine tank to overflow. This drain connection would then carry the excess water to the drain and prevent flooding of the floor. Therefore, no liability will or can be assumed by the manufacturer of the softener should this occur.

- Programming -

The only programming necessary upon installation is to set the hardness:

- Press the **MENU / ENTER** button twice, H-25 will be displayed
- Use the **SET / CHANGE** button to change this setting according to your compensated hardness

-Control Valve Operation/Pressurizing the System-

1. With the unit in bypass (bypass lever is perpendicular to lines), press and hold the set/change button to zero out the meter, and then press and hold set/change again manually index the control valve to BACKWASH (cycle 1).
2. After backwash position has been established, slightly open bypass valve to evacuate excess air from the resin tank. When all air is evacuated, fully open bypass valve. Allow unit to backwash until water runs clear.
3. Press and hold the set/change button to manually index the control valve past the 2nd and 3rd cycles to BRINE REFILL (cycle 4) and allow brine tank to fill. Unit will return to service when this step is over.
4. Once the valve returns to service, close the bypass valve again and repeat steps 1&2 above to evacuate air from the second tank.
5. Once air has been evacuated and water coming from the second tank runs clear, press and hold the set/change button to index the valve to BRINE RINSE (cycle 2). Check the brine tank to verify that water is being drawn during this step. Allow water to be drawn until the air check closes.
6. Manually index the valve to cycle 3 and then to cycle 4. Allow the unit to refill and return to service on its own.
7. Fill the brine tank with salt to complete setup

-Filling The Brine Tank With Salt-

To expect a high level of performance and reliability, a salt manufactured specifically for water softeners must be used. Salt of this grade is virtually free from dirt and other particulate that would eventually cause the softener to malfunction. A pellet type salt is recommended although any high quality water softener salt (such as solar salt) will suffice. If iron is present in the raw water, use of iron inhibiting salt is recommended. The salt level will decrease after each regeneration cycle. Consequently, the brine tank will need to be checked and replenished periodically.

1. Fill the brine tank with water softener salt as described above. This will be approximately 250 lbs. of salt.

Warning: Do not fill salt above level of the brine tank.

2. Replace brine tank lid.
3. Replace control valve cover.

-Disinfection-

For disinfection of you unit, please follow the Sani-System Procedure on the back of the packet provided.

-Final Check-

1. Be certain the bypass valve is in the SERVICE position.
2. Make sure the electrical cord is connected to an uninterrupted 115 volt outlet.
3. Double check regeneration schedule.
4. Make final check for leaks!
5. Be certain to REGISTER YOUR PRODUCT online at www.clearionwater.com
6. Leave this manual with the unit.

-Operation, Care and Cleaning-

Operation of Bypass Valve

When the lever on the bypass valve is in the SERVICE position, water is directed through the water softener. Water may be bypassed by turning the lever to the BYPASS position on the BYPASS valve (lever is perpendicular to inlet / outlet piping). Water to the home will bypass softener and be untreated.

You should manually bypass the softener if:

1. The outside lines do not bypass the water softener and water is to be used for lawn sprinkling or other similar uses.
2. Servicing the water softener.
3. A water leak from the water softener is evident.
4. Shock treating water well and piping with chlorine or other disinfectant.

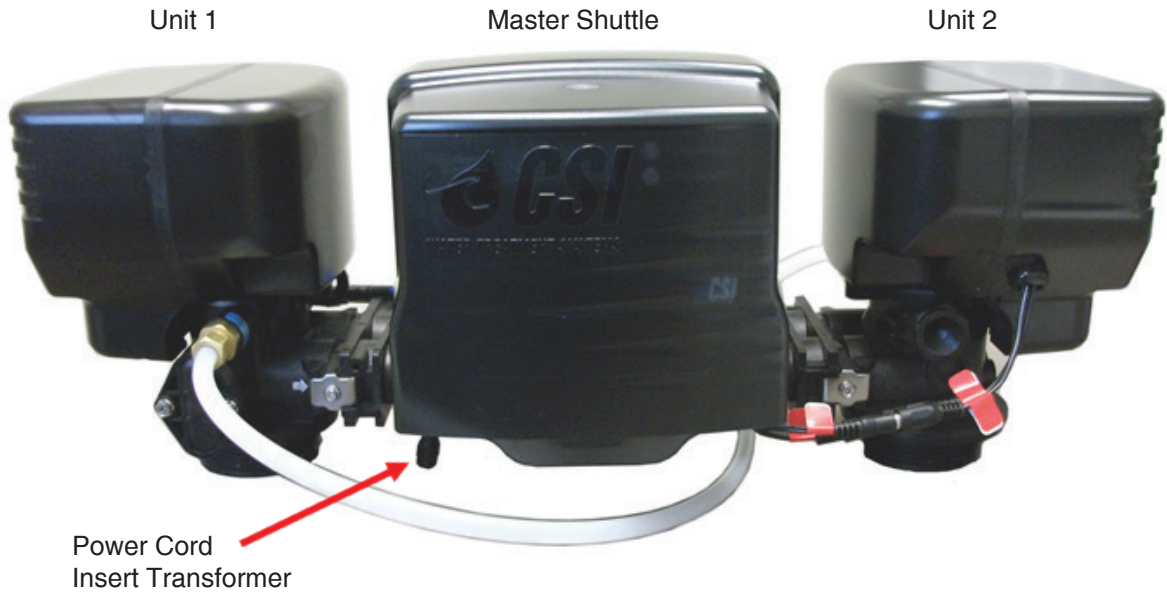

FRONT VIEW

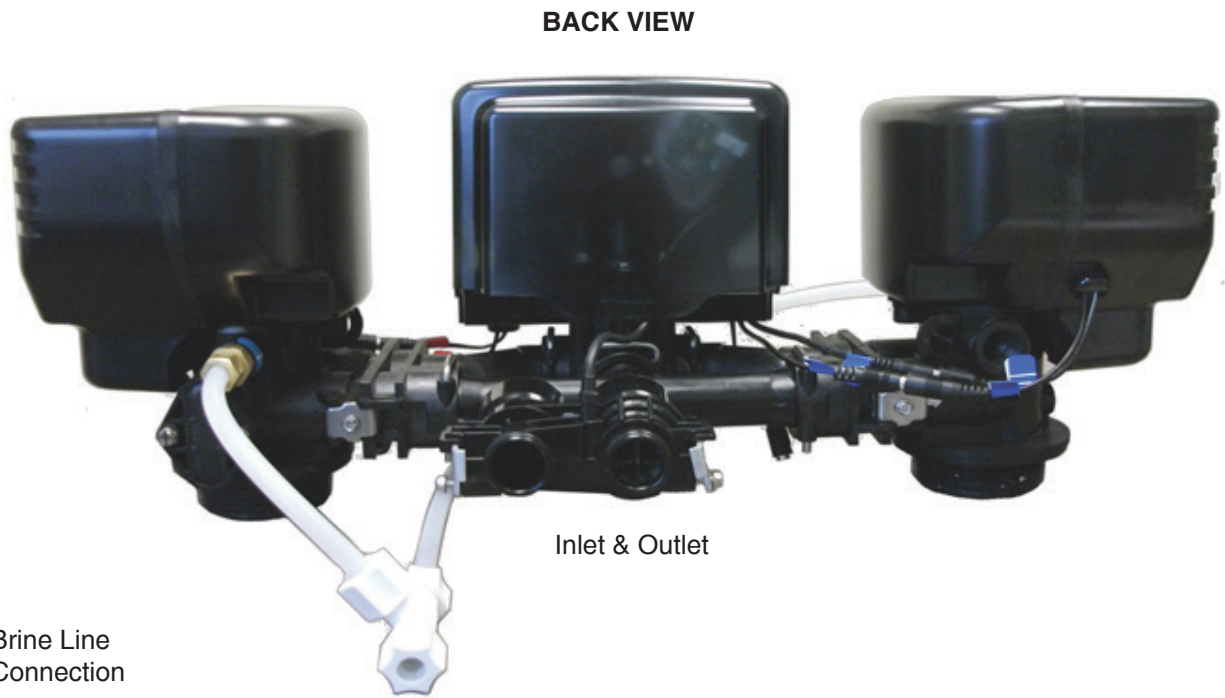

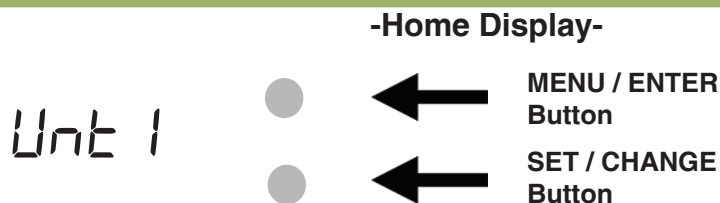

- Alternates between indicating which unit is in service (currently being used to soften the water) and how many gallons are remaining before that unit needs regenerated. If Softener Slave Unit #1 is in service the display will show [Unt1]. If Softener Slave Unit #2 is in service the display will show [Unt2].
- The gallons remaining will decrease as water is used. Once the gallons remaining gets to [0000] the shuttle valve will automatically switch the water flow to the Unit that is in standby.
- During the time that the shuttle valve is shuttling, the display will show the number of the softener unit that it is shuttling to and the last two digits will show rotating segments (ex. [2-"]).
- Once done shuttling the display will again show the Softener Unit that is in service and the gallons remaining. The softener Unit that was just taken out of service will begin its regeneration cycle.
- To view the status of the standby unit, press and release the **MENU / ENTER** button. The display will alternate between the unit number and it's status:
 - If the status shows "r d", this means that the standby unit is ready to go into service when needed
 - If the standby unit is currently regenerating, the display will show the cycle step and the number of minutes remaining (example: 1 - 10)

-Main Menu-

- To enter main menu, press the **MENU / ENTER** button.
- The first menu item is the hardness setting. (ex. [H-25]). The hardness setting should be set according to the water hardness of the water being treated. The hardness setting is used to calculate the number of gallons of water that can be treated between softener unit regenerations.
 - To edit this setting Press the **SET / CHANGE** button.
 - The lowest digit will begin flashing while the other digits are solid.
 - Press **SET / CHANGE** to change the digit to the desired value.
 - Press **MENU / ENTER** to accept the value of the current digit.
 - Repeat last two steps for each digit. ○ Once the last digit is accepted all digits will flash.

*The hardness setting is the only programming necessary upon installation.

- To continue to the next menu item press the **MENU / ENTER** button.
- The third menu item is the regeneration day override setting and will show the current setting (ex. [R-07]), the entire display will be flashing. This setting adjusts the number of days between forced regenerations (if the unit has not been regenerated because of normal water usage). This number will get reset to the programmed setting after any regeneration, and will count down once every 24 hours. If it reaches zero it will force the shuttle valve to switch softener units and will begin regeneration of the unit that leaves service
- To edit this setting Press the **SET / CHANGE** button.
- The lowest digit will begin flashing while the other digits are solid.
- Press **SET / CHANGE** to change the digit to the desired value. ○ Press MENU ENTER to accept the value of the current digit
- Repeat last two steps for each digit.
- Once the last digit is accepted all digits will flash.

Notes: - Maximum Value is 29.

- If value is set to 0, regeneration override will never occur

- To exit the Main Menu press the **MENU / ENTER** button.

Note: While in any part of the Main Menu, if no buttons are pressed for 60 seconds or longer the menu will automatically be exited.

-Starting an Immediate Regeneration Cycle -

- To Start Immediate Extra Cycle, press and hold the **SET / CHANGE** Button to zero out the meter, then repeat.
- After 3 Seconds the Regeneration Cycle will Begin
- The display will show the cycle step and minutes remaining (example "1-10"0 To skip ahead to the next cycle, press and hold **SET / CHANGE** for 3 seconds.

-Flow Meter -

- Hold the **MENU / ENTER** button for approximately 3 seconds in order to view the flow meter.

0531

- The above example shows a water flow of 5.31 gallons per minute (gal/min).

Notes:

1. The smallest continuous detectable flow is approximately 0.35 gal/min.
 2. The flow meter value can be affected by plumbing connections. The value should be considered approximate and should not be used if a highly precise flow reading is needed.
- To exit the Flow Meter Menu press the **MENU / ENTER** button.
Note: While in the Flow Meter Menu, if no buttons are pressed for 60 seconds or longer the menu will automatically be exited.

-Battery Backup-

- To install the battery (standard 9-volt alkaline battery) the cover of the shuttle valve must be removed.
 - Next insert the battery into the battery holding area and snap the 9 volt battery connector onto the battery.
 - Replace the cover.
- Features of Battery Backup
 - The battery backup continues to count down gallons remaining during power failure.
 - If failure occurs while a valve transition is occurring. The battery backup allows a softener slave unit to motor to a rest position that minimizes potential water flow during the power outage. Once power returns, the softener valve will pick back up where it was when power was lost.



During power failures, the display is turned off to conserve battery power. However, to confirm that the battery is working, press either button and the display will turn on for five seconds. When used without battery back-up, the unit acts like a standard mechanical valve—when a power failure occurs, the unit stops at its current point in the regeneration position and then restarts at that point when the power is restored.

-Error Codes -

An error can potentially occur on any of the three valves in the duplex system. If the error occurs on the Shuttle Valve the display will alternate showing [SHUTTLE] and the error code (ex. [ERR2]). If the error occurs on Unit 1 or Unit 2 the display will alternate showing the Unit (ex. [UNIT 1]) and the error code. When an error occurs, it is important to note which valve unit has the error code that is displayed.

There are four (4) error codes which could indicate a possible problem with the control valve:

- Error 2** - Homing slot expected but not found. Valve will begin searching for home (Normal operation continues after valve finds home position)
- Error 3** - Encoder is not sending a position signal
- Error 4** - Unable to find homing slot
- Error 5** - Motor overload (stalled position or shorted motor)

Error 3 Explanation: The unit is not receiving position information from the encoder. This can be caused by the motor not running, or the position encoder not sending a signal. If an Error 3 occurs, first check to make sure all of your wires are plugged in completely. Then unplug the power supply, wait a few seconds and plug it back in. The valve will try to run again, listen for the valve motor trying to run and look to see if the indicator wheel is turning (only applicable for the softener slave Units 1 and 2). If the Error 3 returns again the valve causing the error will need to be serviced.

Error 4 Explanation: The unit is not able to find the home position. The encoder wheel may be partially blocked, or the motor is not running smoothly (has intermittent hesitation or has partial internal gear failure). The valve causing the error will need to be serviced.

Error 5 Explanation: The unit thinks the motor is locked. This can only happen when the valve is running the motor, it is not seeing any change in the position encoder signal, and the motor is overloaded. This usually alerts the presence of corrosion inside the valve clogging the system

-Master Programming Mode -

To enter master programming mode, press and hold both the **MENU / ENTER** button and the **SET / CHANGE** button for 5 seconds.

It is NOT necessary to enter Master Programming Mode. Do not change these settings unless you understand the effect it will have on your softener system, or if Signature Series provider had directed you to make the changes.

Regeneration Cycle Step Times (1)(2)(3)(4) Example [1-10] – Step 1, 10 minutes

- The first 4 items in the Master Programming menu set the duration of time in minutes for each regeneration cycle step.
- The step number which is currently modifiable is indicated on the far left screen. The number of minutes allotted for the selected regeneration is displayed on the far right.

- To edit this setting Press the **SET / CHANGE** button.
- The lowest digit will begin flashing while the other digits are solid.
- Press **SET / CHANGE** to change the digit to the desired value.
- Press **MENU / ENTER** to accept the value of the current digit
- Repeat last two steps for each digit.
- Once the last digit is accepted all digits will flash.
- Press **MENU / ENTER** while all digits are flashing to move to the next menu item.

System Capacity in Grains Example: 032 = 32, 000 grain capacity

Press **MENU / ENTER** button. This display is to set the system capacity in grains and is used in conjunction with the hardness setting to calculate total gallons of treated water available between regenerations. This option is identified by the letter 'c' in the left digit. The maximum value for this item is 399.

- o To edit this setting Press the **SET / CHANGE** button.
- o The lowest digit will begin flashing while the other digits are solid.
- o Press **SET / CHANGE** to change the digit to the desired value.
- o Press **MENU / ENTER** to accept the value of the current digit
- o Repeat last two steps for each digit.
- o Once the last digit is accepted all digits will flash.

To Exit the Master Programming Mode Press the **MENU / ENTER** Button

Note: If no buttons are pressed for 60 seconds, the Master Programming Mode will be exited automatically.

Shuttle Powerhead

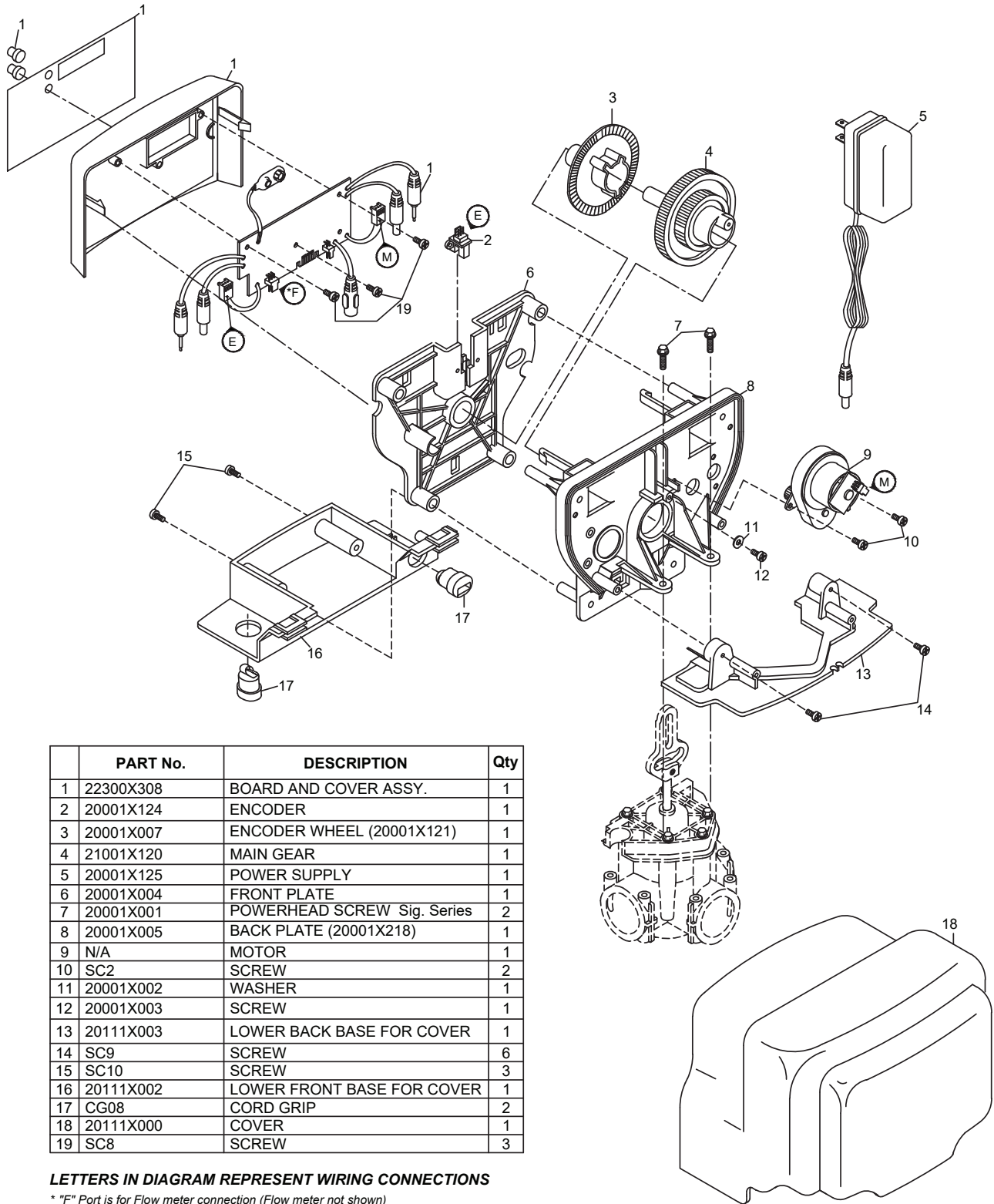

	PART No.	DESCRIPTION	Qty
1	22300X308	BOARD AND COVER ASSY.	1
2	20001X124	ENCODER	1
3	20001X007	ENCODER WHEEL (20001X121)	1
4	21001X120	MAIN GEAR	1
5	20001X125	POWER SUPPLY	1
6	20001X004	FRONT PLATE	1
7	20001X001	POWERHEAD SCREW Sig. Series	2
8	20001X005	BACK PLATE (20001X218)	1
9	N/A	MOTOR	1
10	SC2	SCREW	2
11	20001X002	WASHER	1
12	20001X003	SCREW	1
13	20111X003	LOWER BACK BASE FOR COVER	1
14	SC9	SCREW	6
15	SC10	SCREW	3
16	20111X002	LOWER FRONT BASE FOR COVER	1
17	CG08	CORD GRIP	2
18	20111X000	COVER	1
19	SC8	SCREW	3

LETTERS IN DIAGRAM REPRESENT WIRING CONNECTIONS

* "F" Port is for Flow meter connection (Flow meter not shown)

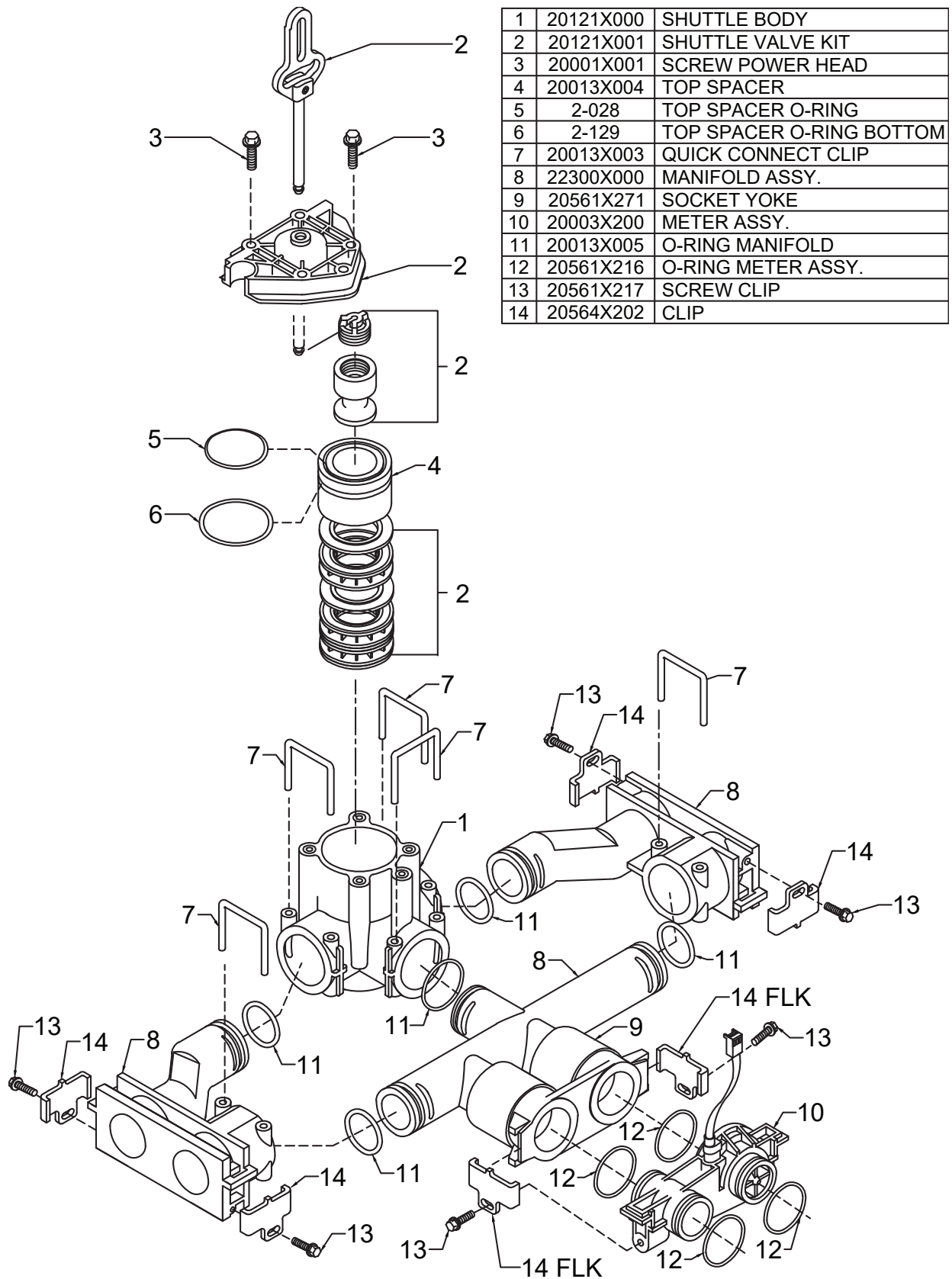

1	20121X000	SHUTTLE BODY
2	20121X001	SHUTTLE VALVE KIT
3	20001X001	SCREW POWER HEAD
4	20013X004	TOP SPACER
5	2-028	TOP SPACER O-RING
6	2-129	TOP SPACER O-RING BOTTOM
7	20013X003	QUICK CONNECT CLIP
8	22300X000	MANIFOLD ASSY.
9	20561X271	SOCKET YOKE
10	20003X200	METER ASSY.
11	20013X005	O-RING MANIFOLD
12	20561X216	O-RING METER ASSY.
13	20561X217	SCREW CLIP
14	20564X202	CLIP

Slave Powerhead

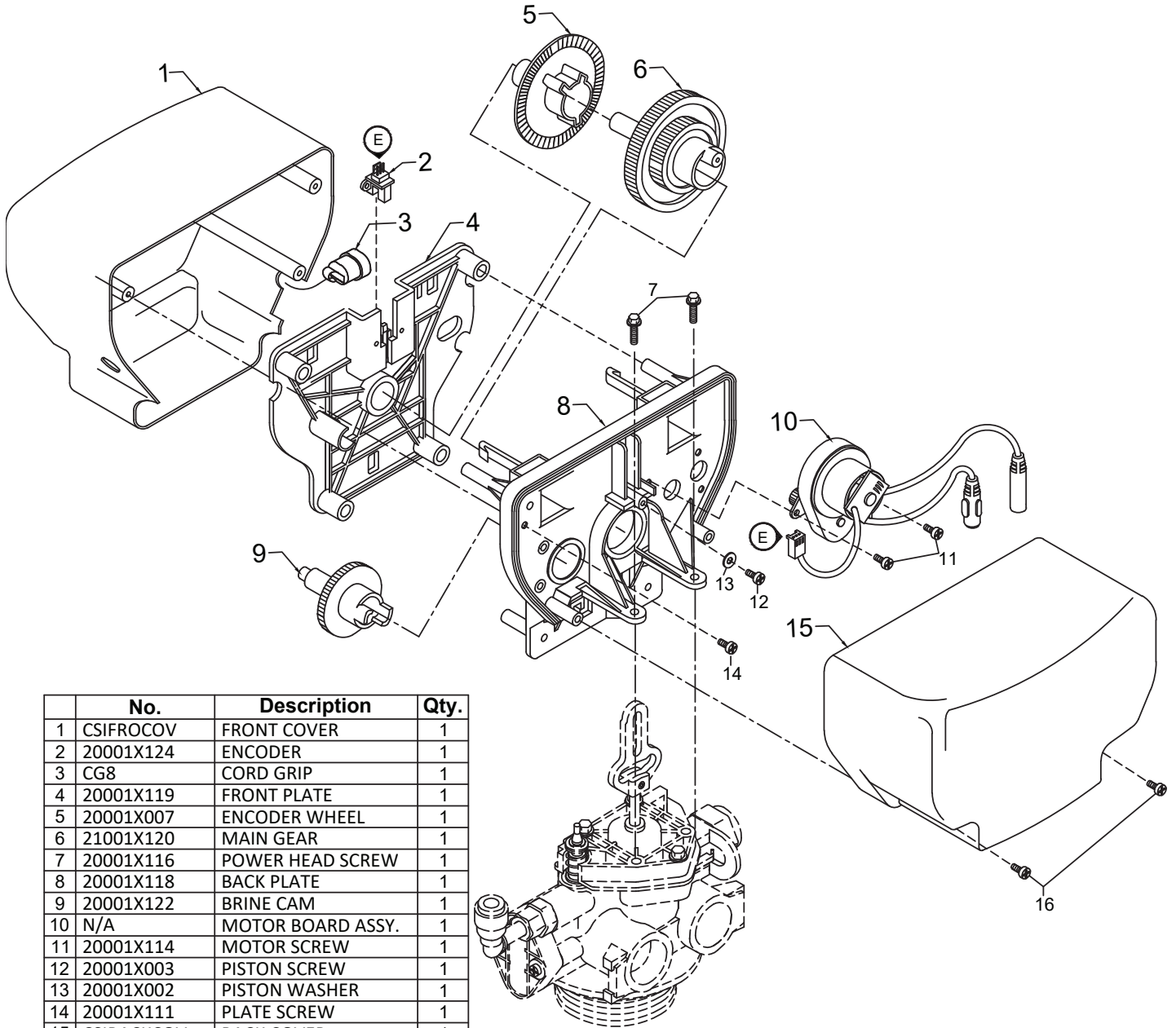

No.	Description	Qty.	
1	CSIFROCOV	FRONT COVER	1
2	20001X124	ENCODER	1
3	CG8	CORD GRIP	1
4	20001X119	FRONT PLATE	1
5	20001X007	ENCODER WHEEL	1
6	21001X120	MAIN GEAR	1
7	20001X116	POWER HEAD SCREW	1
8	20001X118	BACK PLATE	1
9	20001X122	BRINE CAM	1
10	N/A	MOTOR BOARD ASSY.	1
11	20001X114	MOTOR SCREW	1
12	20001X003	PISTON SCREW	1
13	20001X002	PISTON WASHER	1
14	20001X111	PLATE SCREW	1
15	CSIBACKCOV	BACK COVER	1
16	20001X111	COVER SCREW	1
	22300X200-PH	SLAVE POWERHEAD	

LETTERS IN DIAGRAM REPRESENT WIRING CONNECTIONS

	PART No.	DESCRIPTION	Qty.
1	20001X228	BLFC ASSY. (.5 GPM)	1
2	20561X225	BRINE VALVE	1
3	20251X215	COUPLERS	2
4	20001X214	DRAIN CLIP	1
5	20017X266	DRAINLINE 90° HOSE BARB	1
6	20017X250	DLFC ASSY. (Specify GPM Size)	1
7		DLFC BUTTON (Specify GPM Size)	1
8	20017X254	DLFC O-RING	1
9	20001X219	INJECTOR ASSY.	1
10	20001X224	INJECTOR CAP SEAL	1
11	20001X222	INJECTOR SCREEN	1
12	20001X231	PISTON ASSY.	1
13	20561X253	SEAL SPACER KIT	1
14	20561X205	TANK O-RING	1
	22300X101	UNIT 1, RIGHT VALVE ASSY.	1
	22300X102	UNIT 2, LEFT VALVE ASSY.	1

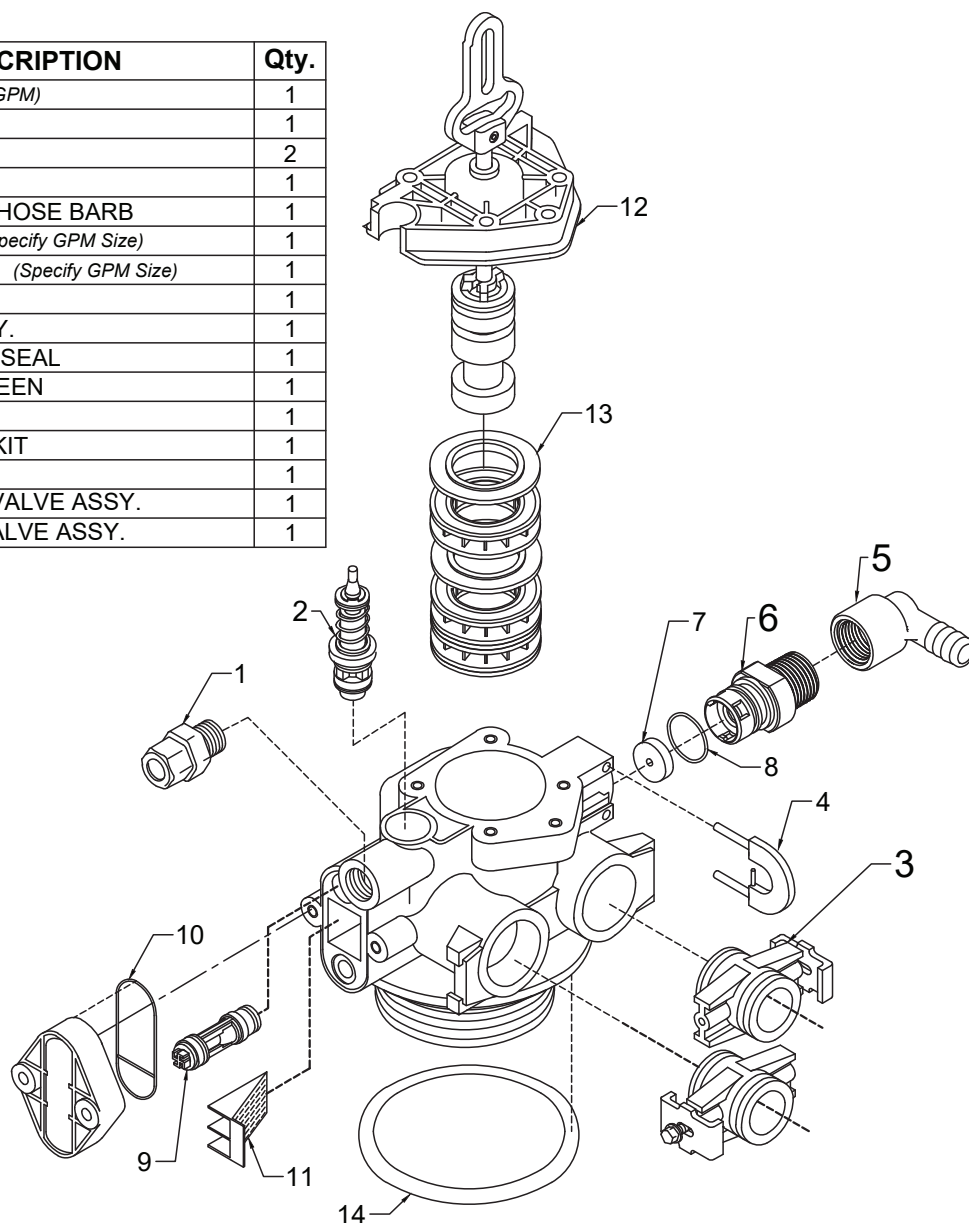

SYMPTOM	PROBABLE CAUSE	CORRECTION
1. Softener Fails to Regenerate Automatically	Power supply plugged into intermittent or dead power source	Connect to constant power source
	Disconnected meter cable	Reconnect cable
	Improper control valve programming	Reset program settings
	Defective power supply	Replace power supply
	Meter is dirty or defective	Clean or replace meter assembly
2. Loss of Capacity	Increased raw water hardness	Increase hardness setting or decrease days between regeneration
	Brine concentration and or / quantity	Keep brine tank full of salt at all times. Clean it yearly. Salt may be bridged. Ensure refill water is over it.
	Resin fouling	Call dealer. Find out how to confirm it. Clean the resin and prevent future fouling.
	Poor distribution, channeling (uneven bed surface)	Call dealer. Check backwash flow. Regenerate more frequently
	Internal valve leak	Call dealer. Replace spacers, seals and / or piston
	Resin age	Call dealer. Check for resin oxidation caused by chlorine. Mushy resin.
	Resin loss	Call dealer. Check for correct bed depth. Broken distributor tube. Air or gas in bed: well gas eliminator. Loose brine line.
3. Poor Water Quality	Check items listed in #1 and #2	
	Bypass valve open	Close bypass valve.
	Channeling	Check for too slow or high service flow. Check for media fouling.
4. High Salt Usage	High salt setting	Lower brine tank refill time
	Excessive water in brine tank	See symptom #7
	Constant flow through the unit	Indicates plumbing leak (e.g. toilet tank)
	Regenerating too frequently	Lower hardness setting or increase days between regeneration.
5. Loss of Water Pressure	Scaling / fouling of inlet pipe	Clean or replace pipeline. Pretreat to prevent.
	Fouled resin	Clean resin. Pretreat to prevent.
	Improper backwash setting	Backwash more frequently

SYMPTOM	PROBABLE CAUSE	CORRECTION
6. Excessive Water in Brine Tank and / or Salty Water to Service	Plugged drain line or drain line control	Check flow to drain. Clean drainline flow control button
	Dirty or damaged brine valve	Clean or replace brine valve.
	Plugged injector or screen	Clean injector screen.
	Low inlet pressure	Increase pressure to allow injector to perform properly. (20 psig minimum)
	Excessive brine refill cycle time	Lower brine refill time.
7. Softener Fails to Use Salt	Check items listed in #1	
	Improper control valve programming	Check and reset programming
	Plugged / restrict drain line	Clean drain line and / or flow control button
	Injector and / or screen is plugged	Clean or replace injector and screen
	No water in brine tank	Check for restriction in BLFC. Ensure safety float is not stuck. Check brine tank for leaks.
	Water pressure is too low	Line pressure must be at least 20 psi.
	Brine line injects air during brine draw	Check brine line connections for air leaks
	Internal control leak	Call dealer. Check piston, seals and spacers for scratches and dents.
8. Continuous Flow to Drain	Foreign material in control piston and seals	Call dealer. Clean valve and replace piston and seals.
	Internal control leak	Same as above.
	Valve jammed in backwash, brine or rapid rinse position	Same as above.
	Motor stopped or jammed	Check for jammed piston. Replace piston and seals. Replace motor if motor is unresponsive.



Limited Warranty

WATER TREATMENT EQUIPMENT

This warranty cannot be transferred - it is extended only to the original purchaser or first user of the product. By accepting and keeping this product, you agree to all of the warranty terms and limitations of liability described below.

Important Warning: Read carefully the Clearion Water Treatment Equipment Installation, Operating and Maintenance Instructions Manual to avoid serious personal injury and property HAZARDS and to ensure safe and proper care of this product.

Model Numbers Covered:
Water Softeners, Media Filters and Upflow Filters

*FOR AS LONG AS YOU OWN AND LIVE IN YOUR SINGLE FAMILY HOME, this warranty covers your water treatment equipment, if you are the first user of this Clearion water treatment equipment and purchased it for single family home use - subject to all of the conditions, limitations and exclusions listed below. Purchasers who buy the Clearion water treatment equipment for other purposes, and other component parts are subject to more limited warranties and you should read all of the terms included in this form to make sure you understand your warranty.

What is covered by this warranty?

Clearion warrants that at the time of manufacture, the water treatment equipment shall be free from defects in material and workmanship as follows :

Residential Mineral Tanks.....	10 years
Proprietary Control Valves	7 years
Other Softener/Filter Control Valves	5 years
Brine Tank	5 years
Residential Reverse Osmosis System.....	5 year
Other Accessories & Parts.....	1 year
Brine Tank Components.....	1 year
REVERE Wireless Low Salt Alarm.....	90 days

* This warranty does not include media and/or cartridge filter elements.

Additional Terms & Conditions

What Clearion will do if you have a covered warranty claim
Clearion will at its option either make repairs to correct any defect in material or workmanship or supply and ship either new or used replacement parts or products. Clearion will not accept any claims for labor or other costs.

Additional Exclusions and Limitations

This warranty is non-transferable and does not cover any failure or problem unless it was caused solely by a defect in material or workmanship. In addition, this warranty shall not apply :

- If the water treatment equipment is not correctly installed, operated, repaired and maintained as described in the Installation, Operating & Maintenance Instructions Manual provided with the product.
- Defects caused as a direct result of the incoming water quality
- If the tank is not the size indicated for the supply line size of the installation, as described in the manual.
- If the unit has not always been operated within the factory calibrated temperature limits, and at a water pressure not exceeding 125 psi

- To any failure or malfunction resulting from abuse (including freezing), improper or negligent; handling, shipping (by anyone other than Clearion), storage, use, operation, accident; or alteration, lightning, flooding or other environmental conditions;
- To any failure or malfunction resulting from failure to keep the unit full of potable water, free to circulate at all times; and with the tank free of damaging water sediment or scale deposits;
- This warranty does not cover labor costs, shipping charges, service charges, delivery expenses, property damage, administrative fees or any costs incurred by the purchaser in removing or reinstalling the water treatment equipment.
- The warranty does not cover any claims submitted to Clearion more than 30 days after expiration of the applicable warranty, and does not apply unless prompt notice of any claim is given to an authorized Clearion Dealer or to Clearion or a designated contractor is provided access to the installation and to the water treatment equipment.

THESE WARRANTIES ARE GIVEN IN LIEU OF ALL OTHER EXPRESS WARRANTIES. NO CLEARION REPRESENTATIVE OR ANY OTHER PARTY IS AUTHORIZED TO MAKE ANY WARRANTY OTHER THAN THOSE EXPRESSLY CONTAINED IN THIS WARRANTY AGREEMENT.

Additional Warranty Limitations

ANY IMPLIED WARRANTIES THE PURCHASER MAY HAVE, INCLUDING THE IMPLIED WARRANTIES OF MERCHANTABILITY AND FITNESS FOR A PARTICULAR PURPOSE, SHALL NOT EXTEND BEYOND THE APPLICABLE TIME PERIODS SPECIFIED ABOVE. Some states do not allow limitations on how long an implied warranty lasts, so the above limitations may not apply to you.

Limitations of Remedies

The remedies contained in this warranty are the purchaser's exclusive remedies. In no circumstances will Clearion or the seller of the product be liable for more than, and purchaser-user's remedies shall not exceed, the price paid for the product. In no case shall Clearion or seller be liable for any special, incidental, contingent or consequential damages. Special, incidental, contingent and consequential damages for which Clearion is not liable include, but are not limited to, inconvenience, loss or damage to property, consequential mold damage, loss of profits, loss of savings or revenue, loss of use of the products or any associated equipment, facilities, buildings or services, downtime, and the claims of third parties including customers. Some states do not allow the exclusion or the limitation of incidental or consequential damages, so the above limitations or exclusion may not apply to you.

What to do if you have a problem covered by this warranty

Any warranty coverage must be authorized by Clearion. Contact the person from whom you purchased the product, who must receive authorization from a Clearion Dealer .

If your product is new and not used and you wish to return it, contact your Clearion Dealer.

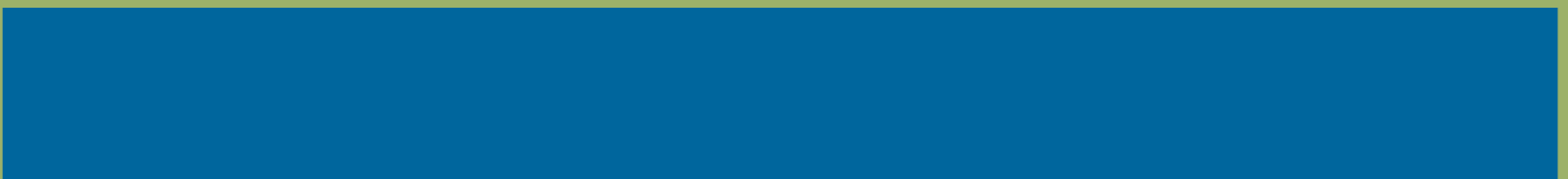



WATER TECHNOLOGIES

710 Orange St, Ashland, OH 44805
PH 419-281-8962 | FAX 419-281-2375 | www.clearionwater.com

1018TV